

POS X

POINT OF SALE
SIMPLIFIED

EVO 2D

Barcode Scanner

The POS-X EVO 2D barcode scanner delivers fast, highly accurate scans of traditional barcodes as well as the increasingly popular 2D codes. It can also scan digital displays including mobile devices, making it great for reading mobile coupons. Rapid, accurate scanning combined with an ergonomic design make the EVO 2D perfect for reading shipping details, recording inventory, or scanning IDs in restaurants, bars, and cafes. At a price point that is hard to beat, the EVO 2D is the clear choice for the future.



Key Features

- Reads 2D and traditional barcodes
- Hands-free image capture mode
- Reads images outdoors in direct sunlight
- Great for use in demanding environments such as airports, trains, and banks
- Reading distance: .9"–14"
- 5-Year warranty includes 2-Day Advance Exchange service

barcode scanner

EVO 2D Specifications

PART NUMBER	EVO-SG1-ADU
PERFORMANCE	
Light Source	White LED
Sight	Red LED, 617 nm
Visual Indicators	Green = decoding successful; Red = decoding failed
System Interface	USB
Typical Depth of Field	5 mm Code39: 33–95 mm (1.3–3.7") 13 mm UPC-A: 32–255 mm (1.3–10.0") 20 mm Code 39: 5–355 mm (1.4–14.0") 6.7 mm PDF417: 30–95 mm (1.2–3.7") 10 mm Data Matrix: 30–100 mm (1.2–3.9") 15 mm Data Matrix: 30–100 mm (1.2–3.9") 20 mm QR: 23–200 mm (0.9–7.9")
Resolution	.8" (20 mm) max
Scanning Angle	Pitch ± 70° Tilt ± 60° Rotation ± 180°
Motion Tolerance	3.9inch/s (100mm/s)
Print Contrast	Minumum 35% contrast
Ambient Light Rejection	0–100,000 LUX
FEATURES	
Autosense Mode	Yes
Supported Symbologies	1D: Code 128, Code 39, Extended Code 39, Code 93, EAN 13, EAN 8, EAN Bookland, Industrial 2 of 5, Interleaved 2 of 5, Logmars, OPC, SCC-14, UCC/EAN Shipping, UPC Shipping Container Code, UPC-A, UPC-E
Programmable Features	Scan mode, prefix code, postfix code, code type, Supplements, Redundant scans, Transmission delay, keyboard Layout, Beep volume, Mobile Phone read mode, Data Editing
PHYSICAL	
Weight	.26 lb (117 g)
Housing	ABS
Dimensions	(LxWxH) 6.5" (165mm)x 2.8" (70mm)x 3.7" (95 mm)
Color	Black
ELECTRICAL	4–5.5 VDC ± 0.25 V (input)
CURRENT	400mA
ENVIROMENTAL	
Temperature	32°– 104°F (0°C to 40°C) (operating) -40°– 140°F (-40°C to 60°C) (storage)
Humidity	5% – 95% relative humidity, non-condensing
Shock Resistance	Withstands multiple drops from 3.3' (1 m)
WARRANTY	5-Year Includes 2-Day Advance Replacement Service
CERTIFICATIONS	SELV, CSA, CDRH

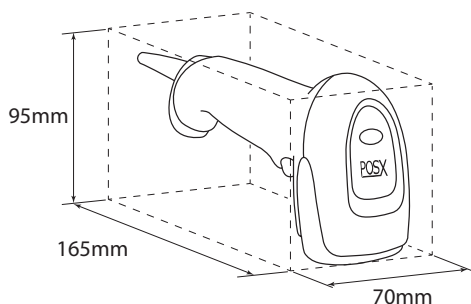

ACCESSORIES

EVO-SG1-ASTAND	EVO Scanner Stand
----------------	-------------------

Legacy Technology Services

We Rent & Sell All Types Of Barcode Equipment

Call now to talk to an expert

866-271-9891

www.LegacyGlobal.com

Some brands we carry



MOTOROLA

Intermec

DATALOGIC™

Honeywell

EQUINOX
PAYMENTS

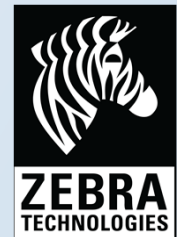

About us

- Legacy Technology Services is a leading nationwide provider of mobile computing, barcode, printers and point of sale equipment and services.
- For over a decade, thousands of clients across North America have trusted us to provide equipment from leading manufacturers backed by the services to support them.

Latest Hardware from top manufacturers

- Legacy handles virtually every major manufacturer of mobile computing, barcoding and point of sale equipment.

Expert Repair and Maintenance services

- Legacy is one of the best repair facilities in North America

Discontinued product sourcing

- They don't make it anymore? Our inventory also includes manufacturer close-outs and discontinued equipment to support our clients legacy infrastructure.

Trade-in and Disposal services

- That old equipment laying around your facility may still have some value. Legacy routinely purchases equipment from our clients around the globe.
 - Data destruction
 - Hardware disposal
 - Auditing services

Dedicated client account team

- Dedicated, highly trained account managers are here to answer all your questions and provide top notch service.

Equipment rental services

- Sometimes renting is a better solution, Legacy's huge rental inventory provides the equipment you need for temporary needs and projects.



Legacy, Inc.

160 West Road,
Ellington, CT 06029

Toll Free: 866-271-9891

Fax: 888-522-4684